



DRIVER: Derek Woof  
 EVENT: MDRA Omaha  
 CLASS: Mod LM  
 TRACK: Hobbyplex Omaha, NE

Clay  Hard Packed  Loose Dirt  
 Carpet  Asphalt  Concrete  
 Flat  Banked  True Oval  Tri-Oval  
 Traction:  High  Medium  Low

|   |                          |              |
|---|--------------------------|--------------|
| <b>LEFT</b>   | <b>FRONT SUSPENSION</b>  | <b>RIGHT</b> |
| <u>+2</u>   | <b>CAMBER</b>            | <u>-0.5</u>  |
| <b>CASTOR</b>   |                          |              |
| <input type="checkbox"/> +10° <input type="checkbox"/> +5° <input checked="" type="checkbox"/> 0° <input type="checkbox"/> -5° <input type="checkbox"/> -10° <input type="checkbox"/> +10° <input type="checkbox"/> +5° <input checked="" type="checkbox"/> 0° <input type="checkbox"/> -5° <input type="checkbox"/> -10° |                          |              |
| <b>ACKERMANN</b>  |                          |              |
| <input type="checkbox"/> OUTER <input checked="" type="checkbox"/> MIDDLE <input type="checkbox"/> INNER <input type="checkbox"/> INNER <input checked="" type="checkbox"/> MIDDLE <input type="checkbox"/> OUTER   |                          |              |
| <u>.125</u>   | <b>AXLE SHIMS</b>        | <u>0</u>     |
| <b>OUTER CAMBER LINK LOCATION</b>   |                          |              |
| <input checked="" type="checkbox"/> OUTER <input type="checkbox"/> INNER <input type="checkbox"/> INNER <input checked="" type="checkbox"/> OUTER   |                          |              |
| <input checked="" type="checkbox"/> 0° <input type="checkbox"/> ANGLED <b>KINGPIN INCLINE</b> <input type="checkbox"/> ANGLED <input checked="" type="checkbox"/> 0°  |                          |              |
| <u>.125</u>   | <b>CAMBER RATE SHIMS</b> | <u>0</u>     |
| <b>SUSPENSION LOCATION</b>  |                          |              |
| <input type="checkbox"/> OUTER <input checked="" type="checkbox"/> MIDDLE <input type="checkbox"/> INNER <input type="checkbox"/> INNER <input checked="" type="checkbox"/> MIDDLE <input type="checkbox"/> OUTER   |                          |              |
| <b>KICK-UP:</b> <input type="checkbox"/> 15° LO <input type="checkbox"/> 15° HIGH <input type="checkbox"/> 20° LO <input type="checkbox"/> 20° HIGH <input checked="" type="checkbox"/> 25° <input type="checkbox"/> 35°  |                          |              |
| <b>TOE:</b> <input type="checkbox"/> OUT <b>SWAY BAR:</b> <input checked="" type="checkbox"/> NONE <input type="checkbox"/>   |                          |              |

**SHOCK LOCATION:**  
ON SUSP ARM:  A  B  C

**SHOCK LOCATION:**  
 A  B  C  D

-SHADE IN MOUNTING LOCATIONS ON SUSPENSION ARMS, BEARING CARRIER AND SHOCK TOWER.

|  |                 |                 |
|--|-----------------|-----------------|
| <b>TIRES &amp; TRACTION</b>  |                 |                 |
| TIRE TYPE: <input type="checkbox"/> FOAM <input type="checkbox"/> STREET RUBBER <input type="checkbox"/> LOOSE |                 |                 |
| <u>Rebar SS</u>  | <b>COMPOUND</b> | <b>DIAMETER</b> |
| <u>AKA Red</u>   |                 | <b>INSERT</b>   |
| RF: <u>"</u>   |                 | <u>"</u>        |
| LF: <u>"</u>   |                 | <u>"</u>        |
| RR: <u>"</u>   |                 | <u>"</u>        |
| LR: <u>"</u>   |                 | <u>"</u>        |
| CLEANED WITH: _____  |                 |                 |
| TRACTION ADDITIVE: _____   |                 |                 |
| NOTES: <u>Rebars ground to slicks</u>  |                 |                 |

|  |  |  |  |
|--|--|--|--|
| <b>SHOCKS</b>  |  |  |  |
| COLLAR LENGTH  |  | SHOCK LENGTH   |  |
|  |  |  |  |
| <b>LEFT FRONT</b>  |  | <b>RIGHT FRONT</b>   |  |
| <b>BODY LENGTH</b>   |  | <b>BODY LENGTH</b>   |  |
| <input type="checkbox"/> SHORT <input type="checkbox"/> MED <input checked="" type="checkbox"/> LONG |  | <input type="checkbox"/> SHORT <input type="checkbox"/> MED <input checked="" type="checkbox"/> LONG |  |
| <b>SHAFT LENGTH</b>  |  | <b>SHAFT LENGTH</b>  |  |
| <input type="checkbox"/> SHORT <input type="checkbox"/> MED <input checked="" type="checkbox"/> LONG |  | <input type="checkbox"/> SHORT <input type="checkbox"/> MED <input checked="" type="checkbox"/> LONG |  |
| SPRING: <u>CW Yellow</u>   |  | SPRING: <u>CW Red</u>  |  |
| OIL: <u>35 LOSI</u>  |  | OIL: <u>35 LOSI</u>  |  |
| PISTON: <u>M</u>   |  | PISTON: <u>M</u>   |  |
| LENGTH: _____  |  | LENGTH: _____  |  |
| COLLAR: <u>.29</u>   |  | COLLAR: <u>.19</u>   |  |
| <b>LEFT REAR</b>   |  | <b>RIGHT REAR</b>  |  |
| <b>BODY LENGTH</b>   |  | <b>BODY LENGTH</b>   |  |
| <input type="checkbox"/> SHORT <input type="checkbox"/> MED <input checked="" type="checkbox"/> LONG |  | <input type="checkbox"/> SHORT <input type="checkbox"/> MED <input checked="" type="checkbox"/> LONG |  |
| <b>SHAFT LENGTH</b>  |  | <b>SHAFT LENGTH</b>  |  |
| <input type="checkbox"/> SHORT <input type="checkbox"/> MED <input checked="" type="checkbox"/> LONG |  | <input type="checkbox"/> SHORT <input type="checkbox"/> MED <input checked="" type="checkbox"/> LONG |  |
| SPRING: <u>CW Red</u>  |  | SPRING: <u>CW Red</u>  |  |
| OIL: <u>30 LOSI</u>  |  | OIL: <u>30 LOSI</u>  |  |
| PISTON: <u>M</u>   |  | PISTON: <u>M</u>   |  |
| LENGTH: _____  |  | LENGTH: _____  |  |
| COLLAR: <u>.48</u>   |  | COLLAR: <u>.38</u>   |  |

|   |                        |              |
|---|------------------------|--------------|
| <b>LEFT</b>   | <b>REAR SUSPENSION</b> | <b>RIGHT</b> |
| <u>+2</u>   | <b>CAMBER</b>          | <u>-3</u>    |
| <u>-6</u>   | <b>TOE</b>             | <u>2</u>     |
| <b>WHEEL SPACERS</b>  |                        |              |
| <input type="checkbox"/> .250" <input type="checkbox"/> .125" <input checked="" type="checkbox"/> NONE <input checked="" type="checkbox"/> NONE <input type="checkbox"/> .125" <input type="checkbox"/> .250"   |                        |              |
| <b>BEARING CARRIER SPACING</b>  |                        |              |
| RIGHT: <input type="checkbox"/> FWD <input type="checkbox"/> 1-OFF FWD <input type="checkbox"/> MIDDLE <input type="checkbox"/> 1-OFF REAR <input checked="" type="checkbox"/> REAR<br>LEFT: <input type="checkbox"/> FWD <input type="checkbox"/> 1-OFF FWD <input type="checkbox"/> MIDDLE <input type="checkbox"/> 1-OFF REAR <input checked="" type="checkbox"/> REAR |                        |              |
| <input checked="" type="checkbox"/> LONG <input type="checkbox"/> SHORT <b>INNER SUSP MOUNT</b> <input type="checkbox"/> SHORT <input checked="" type="checkbox"/> LONG   |                        |              |
| <b>ANTI-SQUAT SHIMS</b>   |                        |              |
| <input type="checkbox"/> 3° <input type="checkbox"/> 1.5° <input checked="" type="checkbox"/> NONE <input checked="" type="checkbox"/> NONE <input type="checkbox"/> 1.5° <input type="checkbox"/> 3°   |                        |              |
| <b>ROLL CENTER SHIMS</b>  |                        |              |
| <input type="checkbox"/> .125" <input checked="" type="checkbox"/> .060" <input type="checkbox"/> NONE <input type="checkbox"/> NONE <input checked="" type="checkbox"/> .060" <input type="checkbox"/> .125"   |                        |              |
| <b>OUTER CAMBER LINK LOCATION</b>   |                        |              |
| <input checked="" type="checkbox"/> OUTER <input type="checkbox"/> INNER <input type="checkbox"/> INNER <input checked="" type="checkbox"/> OUTER   |                        |              |
| <b>BEARING CARRIER PIN HEIGHT</b>   |                        |              |
| <input checked="" type="checkbox"/> HIGH R.C. <input type="checkbox"/> LOW R.C. (NEAR AXLE) <input type="checkbox"/> LOW R.C. <input checked="" type="checkbox"/> HIGH R.C.   |                        |              |

**SHOCK LOCATION:**  A  B  C  D  E

**SHOCK LOCATION:**  A  B

-SHADE IN MOUNTING LOCATIONS ON SUSPENSION ARMS, BEARING CARRIER AND SHOCK TOWER.

# ROCKET3 STAGE

**RECEIVER**  
 AS SHOWN  
 Behind  
 Servo

**SERVO LOCATION**  
 AS SHOWN  
 CENTERED

**SPEED CONTROL**  
 AS SHOWN  
 Behind  
 Receiver

**ADDED WEIGHT**  
 FRONT \_\_\_\_\_  
 MIDDLE \_\_\_\_\_  
 REAR \_\_\_\_\_

**BATTERY POSITION**  
 AS SHOWN: F     R  
 #3266 STOCK LOCATORS  
 #1294 CARBON LOCATORS  
 INNER  MIDDLE  OUTER  
 OFFSET ON CHASSIS

**TRANNY LOCATION**  
 FORWARD  
 MIDDLE  
 REAR

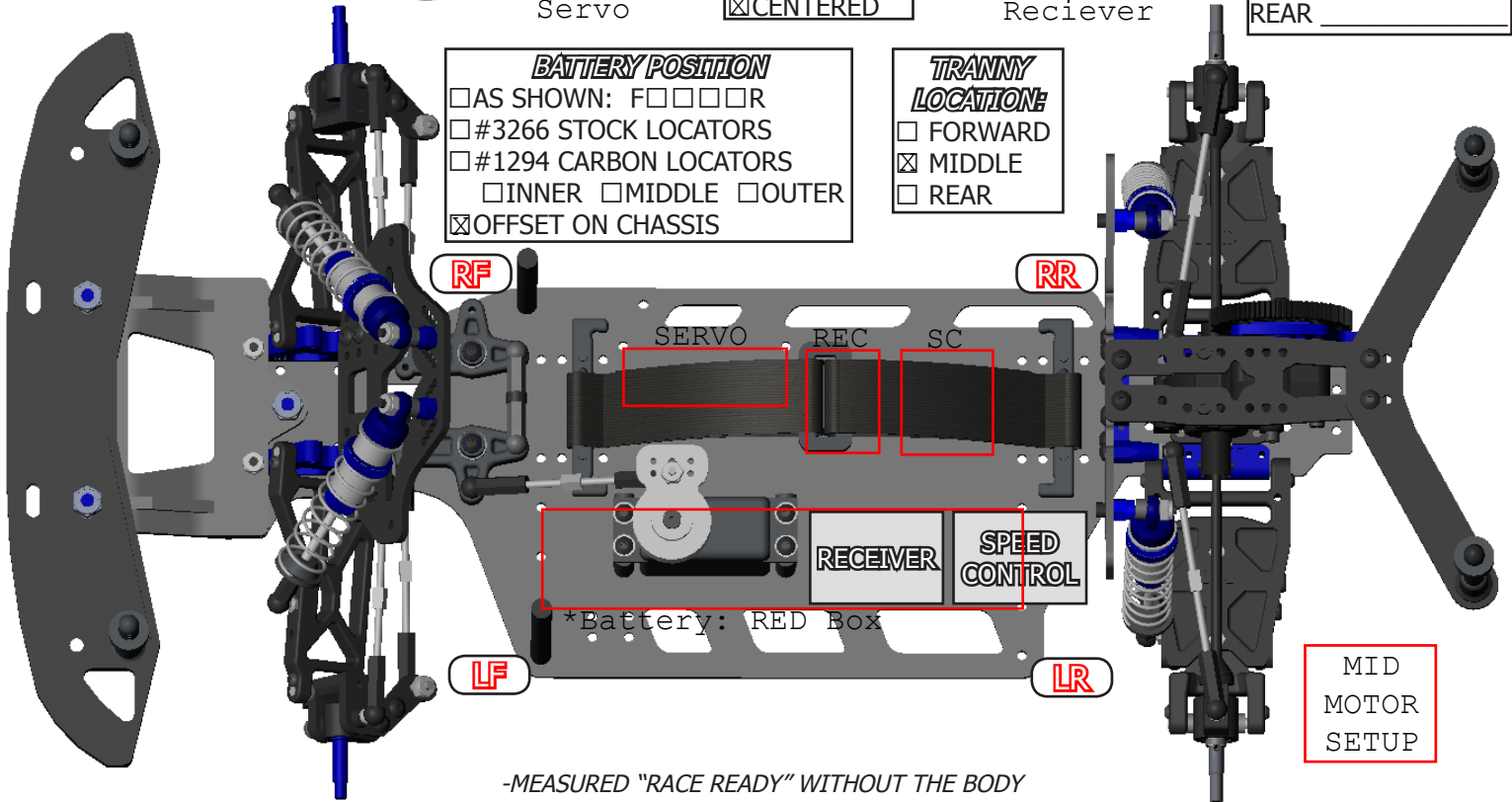

-MEASURED "RACE READY" WITHOUT THE BODY

| <i>RIDE HEIGHTS BY LOCATION:</i>   | <i>CORNER WEIGHTS:</i>                              | <i>MAX CHASSIS HEIGHT:</i>  |
|--|---|---|
| LF: <u>.81</u> RF: <u>.85</u>  | LF: <u>11.9</u> RF: <u>11.3</u>                     | LF: _____ RF: _____   |
| LR: <u>.78</u> RR: <u>.87</u>  | LR: <u>17.6</u> RR: <u>14.0</u>                     | LR: _____ RR: _____   |
| <i>MEASURED FROM:</i><br><input checked="" type="checkbox"/> TOP OF CHASSIS <input type="checkbox"/> BOTTOM OF CHASSIS | <i>OVERALL:</i> _____                               | <i>MEASURED FROM:</i><br><input type="checkbox"/> TOP OF CHASSIS <input type="checkbox"/> BOTTOM OF CHASSIS |
| <b>POWER SETTINGS</b>  | <b>NOTES:</b>                                       |   |
| MOTOR: <u>D4 10.5</u>  | MID MOTOR SETUP                                     |   |
| AMP DRAW: _____  | Pretty much a one off setup for OMAHA (HIGH RUBBER) |   |
| TIMING: <u>40</u>  |   |   |
| PINION: <u>32</u>  |   |   |
| SPUR: <u>90</u>  |   |   |
| SPEED CONTROL:<br><input checked="" type="checkbox"/> "BLINKY" <input type="checkbox"/> OPEN                           |   |   |
| SETTINGS: _____  |   |   |
| BATTERY: <u>RevTech 7150</u>   |   |   |
| MOTOR TEMP AFTER RUN: _____  |   |   |
| <b>AERO</b>  |   |   |
| BODY: <u>CW 9072 Mountaineer</u>   |   |   |
| SPOILER LENGTH: <u>2.50"</u>   |   |   |
| SPOILER ANGLE: <u>HIGH</u>   |   |   |
| WICKERBILL: <u>No</u>  |   |   |
| BOTTOM OF REAR GLASS TO BODY POST CENTER: <u>1.50"</u>   |   |   |